



木料与窄板的完美修边  
**PERFECT TRIMMING CUT**  
 FOR WOOD BLOCK & NARROW PANEL.



**E-CLASS**  
**DET-2000-E6**  
**DOUBLE END TENONER**  
 双端作榫机

型号识别  
**MODEL IDENTIFICATION**

**DET E SERIES**

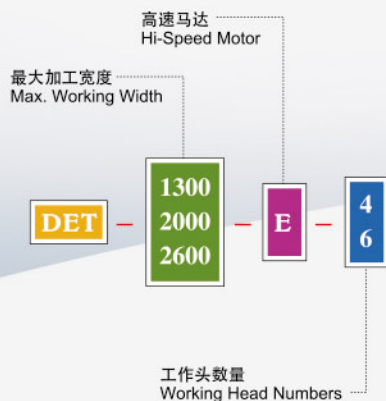

**DET-CE SERIES**

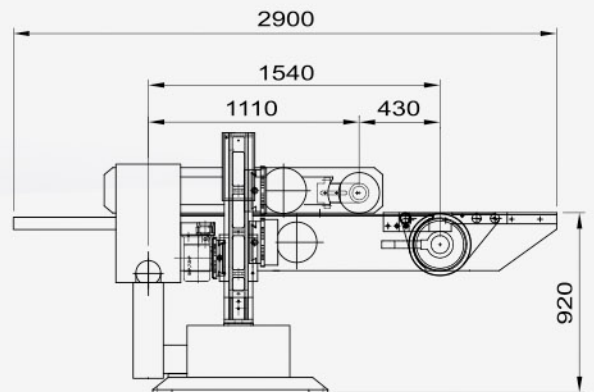
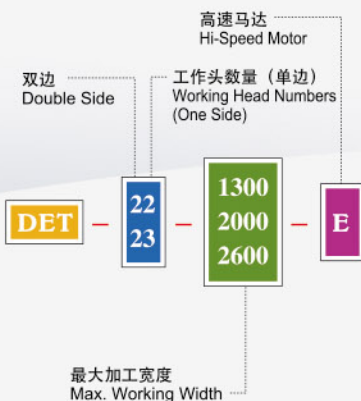

DET-E6-Model尺寸图

## 标准配备 Attractive, Smart and Exclusive Features

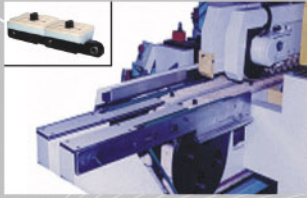

**进给链条装置**  
**Feed chain track system**  
配备精密履带链条，此履带链条装置采防尘及免润滑之针状轴承

Is enriched with precision track linkage mounted with dust-proof and free lubricated needle bearing, to ensure perfect parallel at y-axis.

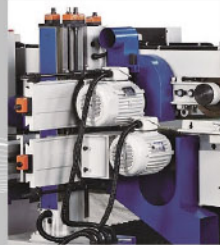

**槽切系统**  
**Scoring saw unit**  
2HP (选配option 3/5HP)  
**主锯系统**  
**Main saw unit**  
5HP (选配option 7.5HP)  
主轴转速Spindle speed: 3000 RPM  
主轴尺寸Spindle dim.: Ø25.4 MM x 82 MM



**成型系统**  
**Moulding unit**  
5HP (选配option 7.5HP)  
主轴转速Spindle speed: 6000 RPM  
主轴尺寸Spindle size.: 40 MM x 120 MM



**自动宽度定寸装置**  
**Electrical positioning device**  
For movable stand with digital read out to control working width

## 选择配件 Optional attachment



**回料装置**  
**Feedback conveyor**  
Transfer the working piece back through the conveyor belt.



**自动送料架**  
**Automatic feeding magazine**



**安全防护网**  
**Safety net**  
Prevent wood dust from spraying



**安全罩**  
**Safety cabinet**

MODEL			DET-E4 (DET-22-E)	DET-E6 (DET-23-E)
工作头数量Working units	pcs		4 (2+2)	6 (3+3)
最大加工宽度Max. working width	mm(ft)		1300 (4) / 2000 (6) / 2600 (8)	
最小加工宽度(双边)Min. working width (on double side)	mm(in)		220 (8-5/8) option 175 (6-7/8)	
最小加工宽度(单边)Min. working width (on single side)	mm(in)		110 (4-3/8) option 90 (3-1/2)	
最大加工厚度Max. working thickness	mm(in)		60(2-9/25) option 100(3-8/9)	
槽切锯系统Scoring saw unit	马达Motor	hp	2 option 3 / 5	
	主轴转速Spindle speed	rpm	3000	
	主轴尺寸Spindle dimension	mm	25.4 x 82 L	
	锯片尺寸Sawblade dimension	mm	255 x 25.4 x 3.0 x 80T	
主锯系统Main sawing unit	马达Motor	hp	5 option 7.5	
	主轴转速Spindle speed	rpm	3000	
	主轴尺寸Spindle dimension	mm	25.4 x 82L	
	锯片尺寸Sawblade dimension	mm	255 x 25.4 x 3.0 x 80T	
成型系统Moulding unit	马达Motor	hp	5 option 7.5	
	主轴转速Spindle speed	rpm	6000	
	主轴尺寸Spindle dimension	mm	40 x 120 L	
	刀具外径Cutter dimension	mm	140-160	
链条系统Chaintrack system	马达Motor	hp	2	2
	进给速度Feed speed	m/min	6~24	
	档块间距Distance between dogs	mm	400 option 300 / 200	
移动系统Movable side	马达Motor	hp	1	
	进给速度Feed speed	m/min	2	
重量Weight	净重Net weight	kgs	3100 (3300) / 3200 (3400) / 3300 (3500)	
	毛重Gross weight	kgs	3500 (3700) / 3600 (3800) / 3700 (3900)	
尺寸Dimension	机器尺寸Machine size	mm	3400 / 4000 / 4600 x 2900 x 1700	
	包装尺寸Packing size	mm	3520 / 4120 / 4720 x 1700 x 1800	

We reserve the right for technical modification.