

標準附件

- 人机介面自动操作模式
- 厚度调整读数表
- 垂直水平调整读数表
- 水平调整读数表
- 进给链条橡胶板披覆
- 红外线照射灯
- 工具箱
- 操作手册

特殊附件

- 安全罩
- 上压梁与进给链条轴心间距由750 MM 增加至1350/1950 MM
- 立轴马达改为变频马达+变频器
- 立轴加装气压式上下导板
- 槽切锯加装跳刀装置
- 立轴加装伺服电动缸跳刀装置
- 捣碎锯
- 移动端导螺杆自动润滑系统
- 余料装置
- 电动式上梁升降

Standard Attachment

- Auto. Positioning device for movable stand to control working width.
- Digital readout device for thickness adjustment of double side
- Digital readout device for vertical adjustment of working heads
- Digital readout device for horizontal adjustment of working heads
- Feed chain track with rubber pad
- Laser light
- Tool box
- Operation manual

Optional Attachment

- Safety cabinet
- Distance between center of bottom chain track and top belt pulley change from 750 mm to 1350/1950 mm
- Moulding saw change to hi-frequency motor with inverter
- Moulding unit with pneumatic top pressure pad + bottom support
- Jumping device for scoring saw unit.
- Jumping device with servo electric cylinder for moulding unit
- Hogging cutters
- Auto. lubrication for movable stand ball screw
- Chip conveyor
- Auto. adjustment for top pressure beam

型號	MODEL	DET-L8 (DET-24)	DET-L10 (DET-25)	DET-L12 (DET-26)	DET-L14 (DET-27)	DET-L16 (DET-28)
工作头数量	Working units	8(4+4)	10(5+5)	12(6+6)	14(7+7)	16(8+8)
最大加工宽度	Max. working width	1300 / 2000 / 2600 / 3200 / 4000 / 5000 / 6000 (mm(ft))				
最小加工宽度(双边)	Min. working width (on double side)	220(8-5/8) option 175(6-7/8) (mm(in))				
最小加工宽度(单边)	Min. working width (on single side)	110(4-3/8) option 90(3-1/2) (mm(in))				
最大加工厚度	Max. working thickness	60(2-9/25) option 100(3-8/9) / 120(4-3/4) / 150(5) (mm(in))				
槽切锯系统 马达	Scoring saw unit Motor	2 option 3 / 5 / 7.5 (hp)				
主轴转速	Spindle speed	3000 rpm				
主轴尺寸	Spindle dimension	25.4 x 82 L (mm)				
锯片尺寸	Sawblade dimension	255 x 25.4 x 3.0 mm x T80 (mm)				
主锯系统 马达	Main sawing unit Motor	5 option 7.5 (hp) / 10 (hp)				
主轴转速	Spindle speed	3000 (rpm)				
主轴尺寸	Spindle dimension	25.4 x 82 L (mm)				
锯片尺寸	Sawblade dimension	255 x 25.4 x 3.0 mm x T80 (mm)				
成型系统 马达	Moulding unit Motor	5 option 7.5 / 10 / 12 / 15 (hp)				
主轴转速	Spindle speed	6000 option 8000 (rpm)				
主轴尺寸	Spindle dimension	40 x 120L (mm)				
刀具外径	Cutter dimension	140-160/220-240 (mm)				
三角环带砂光系统 马达	Belt sanding unit Motor	2 (hp)				
砂带尺寸	Sanding belt size	4" x 60" / 84" / 98" (inch)				
震盪马力	Vibration power	25w x 1/36				
海绵轮/环带砂光系统 马达	Roller / disc sanding unit Motor	2 (hp)				
砂带尺寸	Sanding belt size	4" x 42" (海绵轮砂光系统 sponge sanding unit)				
自动补偿	Auto. compensation	仅限碟型砂光系统 disc sanding only				
链条系统 马达	Chaintrack system Motor	5 / 7.5 (hp)				
进给速度	Feed speed	6-24 (m/min)				
档块间距	Distance between dogs	600 (mm)				
链条正反转	Normal/Reversible	标准配备 Standard				
移动系统 马达	Movable side Motor	1 (hp)				
进给速度	Feed speed	2 (m/min)				

We reserve the right for technical modification.



洪业有限公司 **TECHNIK ASSOCIATES, INC.**
42756 台中市潭子区大丰路一段288号之三
NO. 288-3, Sec. 1, Dafong Rd., Tantzú Dist., Taichung 42756, Taiwan
Tel.: +886-4-2568-8555 · 2534-9000 Fax: +886-4-2534-9160
http://www.hipoint.com.tw
E-mail: hipointmachinery@gmail.com / hptmac@gmail.com



高点机械 台湾精品

重型双端作榫机系列

DOUBLE END TENONER

LUXURY CLASS



我们提供

- 高品质产品
- 高效率产品
- 可靠性产品
- 专业顾问工程
- 专业售后服务

We support to provide

- High quality production
- High efficiency products
- Reliable products
- Specialized consulting & engineering
- Expert after-sales service



洪业有限公司 **TECHNIK ASSOCIATES, INC.**

DET-L Series 系列
DET-CE Standard Series 认证系列

重型双端作榫机
HEAVY DUTY DOUBLE END TENONER

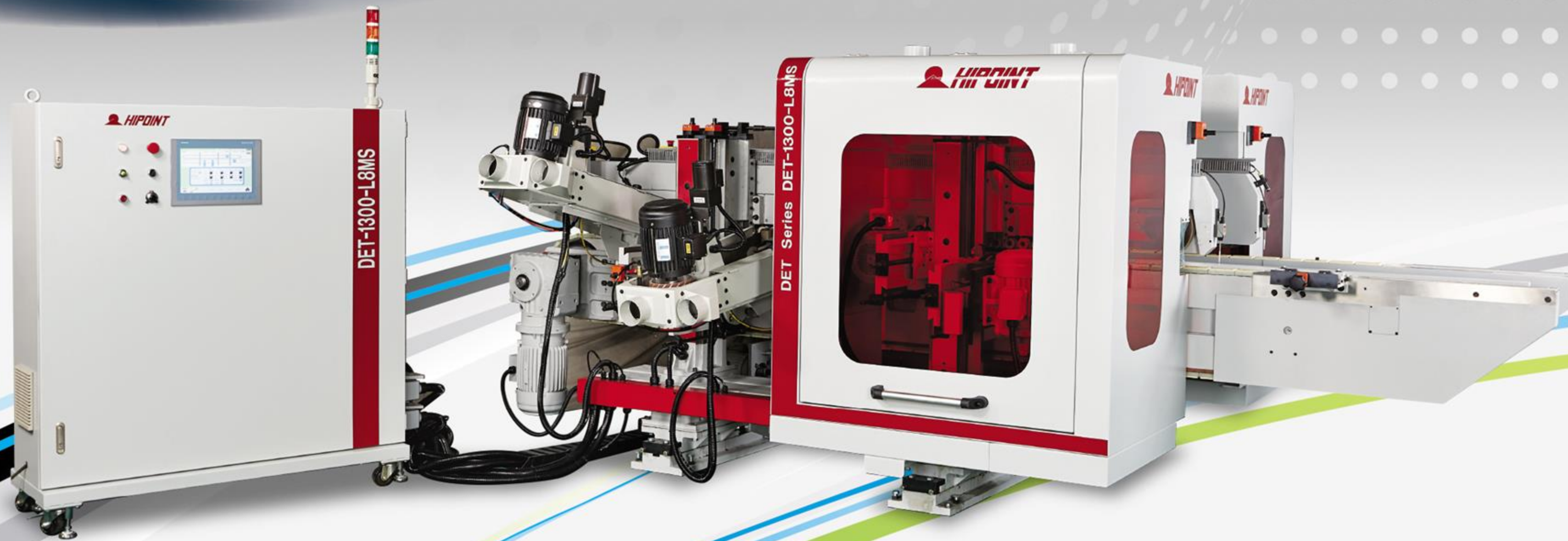

标准配备 Attractive, Smart and Exclusive Features

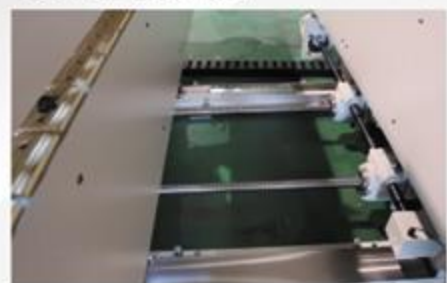

分离式线轨
采用分离式双基座配合滚珠导
螺杆传动
individual linear guide way
Two slide guide way transfer with ball
screw.



进给链条装置
配备精密履带链条，此履带链条
装置探防尘及免润滑之针状轴承
(厂牌:德国INA)
Feed chain track system
Is enriched with precision track linkage
mounted with dust-proof and free
lubricated needle bearing, to ensure
perfect parallel at y-axis.
(BRAND: GERMAN INA)



人机介面自动操作模式
(厂牌:德国西门子)
**PLC Control for automatic
positioning and working
unit operation**
(BRAND: GERMAN SEMENS)



出料端双侧压轮
Double sided pressure roller



槽切锯系统
Scoring saw unit
2HP(option 3/5 HP)
Spindle speed:3000 rpm (50 HZ)
Spindle dim:Ø25.4 x 82 mm(L)



主锯系统
Main saw unit
5HP(option 7.5 HP)
Spindle speed:3000 rpm (50HZ)
Spindle dim:Ø25.4 x 82 mm(L)



立轴系统
Moulding unit
5HP (special 7.5HP)
Spindle speed: 6000 rpm (50HZ)
Spindle size: Ø40 x 120 MM (L)
Option attachment: Jumping device

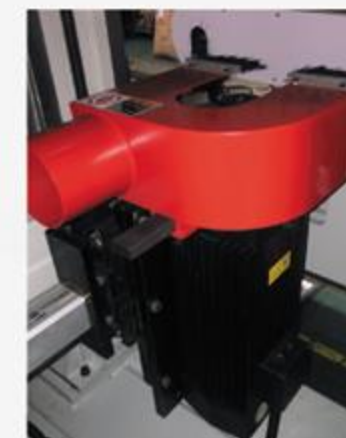

立轴系统(变频马达)
H.F Moulding unit
7.5HP (special 10HP 15HP)
Spindle speed: 3000/6000 rpm (60/120 HZ)
Spindle size: Ø40 x 120 MM (L)
Option attachment: Jumping device

DET-L Series 系列
DET-CE Standard Series 认证系列

重型双端作榫机
HEAVY DUTY DOUBLE END TENONER

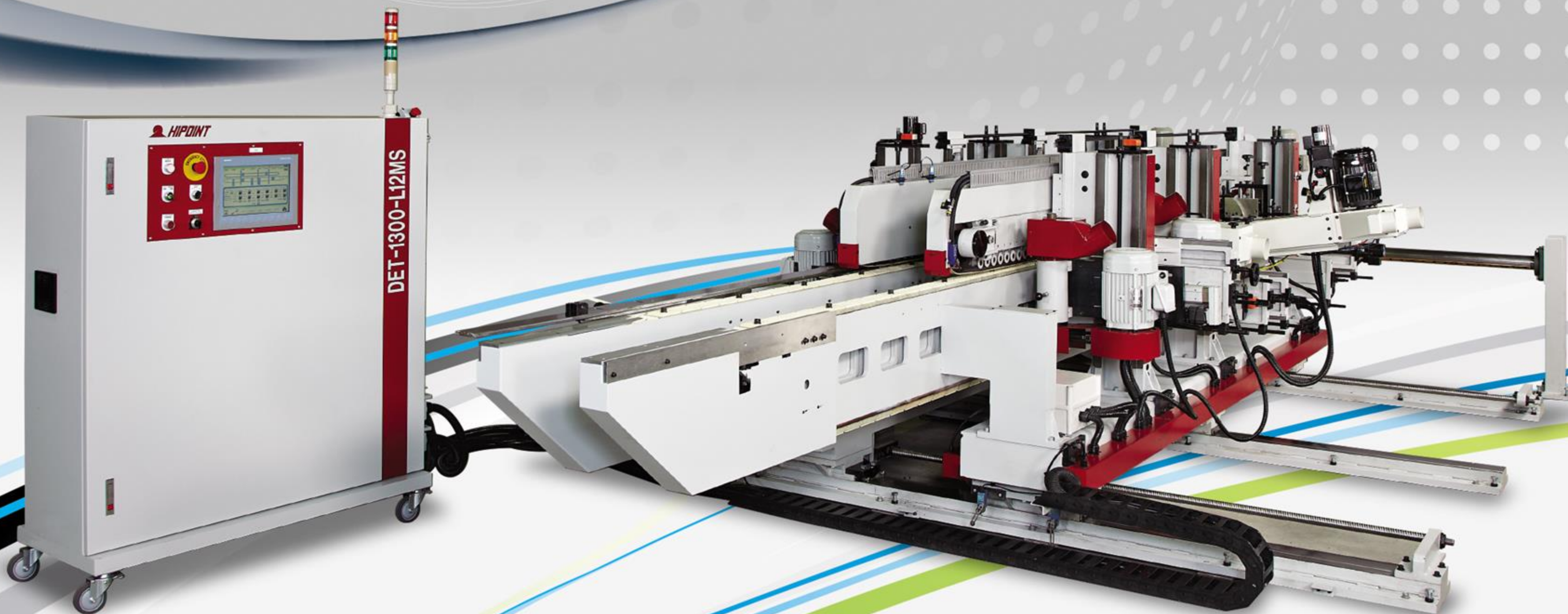

特殊配备 Optional Attachment



立轴加装气压式上下导板
Moulding unit with
pneumatic top pressure
pad+bottom
support (Chrom plated)



自动送料架
Auto. feeding magazine
Working length:220~1300/2000/2600 mm
Working width:50~150 mm
Working height:8~60 mm
Max. working height of magazine:500 mm



余料输送机
Chip conveyor



平面三角环带砂
Belt sanding unit
Motor : 2HP
Sanding belt size : 4" x 60"
Vibration power : 25w x 1/36



成型三角环带砂
Profile belt sanding unit
Motor : 2HP
Sanding belt size : 4" x 98" / 84"
Vibration power : 25w x 1/36



碟型砂光带补偿
Disc sanding unit
Motor : 2HP ,Spindle : 1"x 4"
with vibration motor
with auto. compensation



海绵轮砂带座
Sponge sanding unit
Motor : 2HP
Sanding belt size : 4" x 42"
Sponge roller : 7" x 4"



上下鉋
Top and bottom milling unit
7.5HP (special 10HP 15HP)
Spindle speed:3000/6000 rpm (50/100HZ)
Spindle dimension:Ø40 x 120 mm (L)

DET-L Series 系列

DET-CE Standard Series 认证系列

型号识别

MODEL INTRODUCTION

用途

此款机种为新型双边同时加工之多功能複合机，定义为豪华重型机种(L-CLASS)，为双边工作单元为8轴以上之豪华複合型加工机，并可依客户需求特殊订製，可结合定寸、成型、封边、砂光、导角、开槽等边缘加工，并施以模组化生产。

此机种跳脱一般双端铣之固定式基座，採用分轨式轨道基座，依据工作要求机身可长达10米，不再受固定式基座限制，此分轨式轨道基座针对整机加工而言可将机器重心平均分配于基座轨道上，使工作在加工时平稳，不会因重心分配不均，工件加工完产生加工面顿挫。

特性

- 客製化的工作头排列可完美达到客户产品所需之加工。
- 高精度线性滑轨：基座的移动採用高精度之线性滑轨，可确保X轴移动时能形成完美的平行。
- 进给链条装置：配备精密履带链条，此履带链条装置採防尘及免润滑之针状轴承，可确保Y轴移动时形成完美的平行线。
- 高精度线性滑轨+进给链条装置，促成机器呈现双十字的运动，以保证其直角度。
- 人机介面自动定位装置：人机介面控制，尺寸调整包含公制，英制及台制等多种选择，而且无须微调。

Application

New type of bilateral multi-function compound machine is designated as a luxury heavy-duty machine (L-CLASS), and defined as a bilateral working unit for more than 8-axis luxury composite processing machine. This new type machine can be customized based on customers' demands, including sizing, moulding, edge banding, sanding, chamfering, grooving and other edge processing, and impose modular production.

We use individual slide guide ways instead of single base slide guide way. Depends on the requirements, lengths of the machine can reach more than 10 meters without the restriction from single base slide guide way. Moreover, benefited from individual slide guide ways, processing will be more stable as the center or gravity can be evenly distributed on the individual slide guide ways, generating smooth machine surface.

Features

- Customized working unit line can perfectly reach the product processing of customer's requirement.
- The machine sliding on high precision linear guide way to get perfect parallel at x-axis.
- Feed chain track system is enhanced with precision track linkage mounted with dust-proof and free lubricated needle bearings to ensure perfect parallel at y-axis.
- The high precision linear guide way + feed chain track form double crisscross movement to guarantee squaring.
- Automatic positioning device with digital readout in metric, inches or Japanese inches for various operation.
- No micro-adjustment required.



安全锁
Safety Lock



CE标准配电盘
CE Proved Electric Control Board



鍊条传动机构
Gear Transmit System



直径传动轴
Double Key Transmission Shaft

DET-L SERIES 系列

最大加工宽度
Max. Working Width

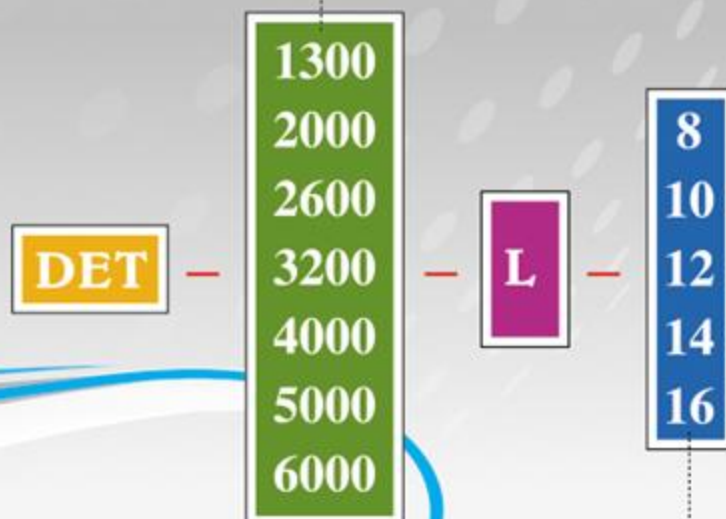

工作头数量
Working Head Numbers

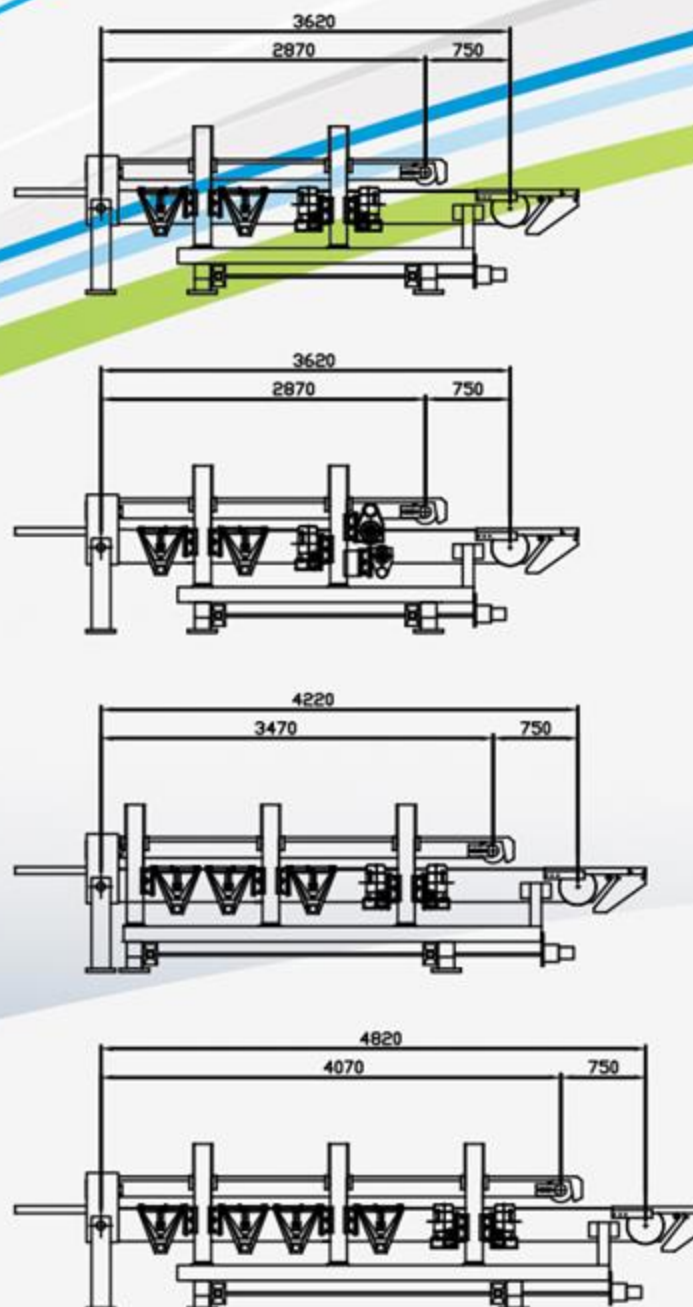

DET-CE SERIES 认证系列

双边
Double Side

工作头数量(单边)
Working Head Numbers (One Side)

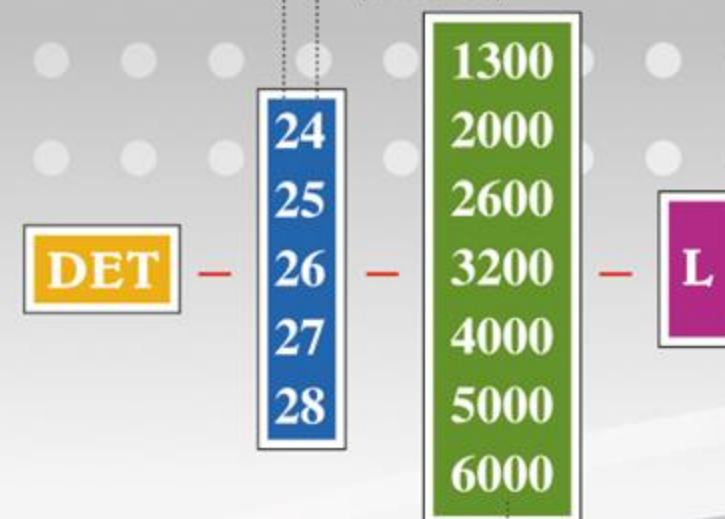

最大加工宽度
Max. Working Width

